

PRODUCTS - Control valves

18 INCH HYDRANT PIT BOX GBMY 4000

Avery-Hardoll brand hydrant pits have always proved their reliability and safety. These quality products are widely used and accepted by airport authorities and oil companies throughout the world.



- New improved specification allows for easy maintainance.
- Insensitive to ground movement.
- Durable cast iron pit body-finished in white epoxy internal and intertuf external surfaces.
- Aluminium cover with non-slip surface is lightweight and easy to handle.
- Accepts a wide range of internals, including competitors valves conforming to API recommendations.
- Optional blanking flange available.
- Optional static bonding strip.

Installation

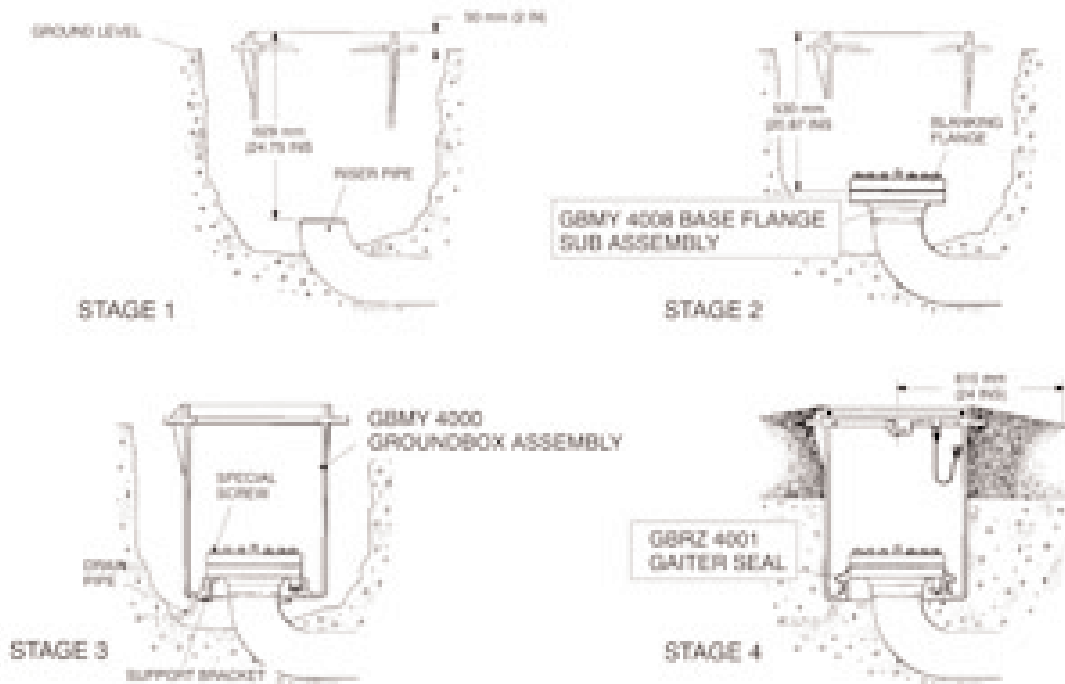

Overall dimensions

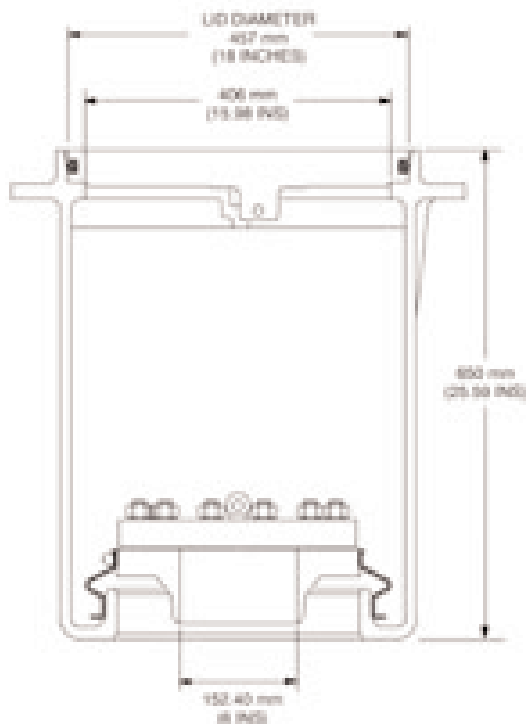

Optional extras

GBMY3000 BLANKING FLANGE AND GASKET

The purpose of the blanking flange and gasket is to enable the hydrant system to be flushed and pressure tested prior to commissioning without damage to the valve. It is also fitted when the valve is removed for service / repair.

GBMY4009 STATIC BONDING STRIP AND FITTINGS

The strip will prevent any static shock which may occur in the normal use of the system.

GBMY3005 EXTENDED COMBINATION SPANNER

A double headed spanner with a 11/8" CROWS FOOT at one end and a 11/8" AF socket at the other to facilitate torque tightening of flange nuts.

Specifications

NEW GAITER SEAL.

A new gaiter seal has been fitted to the 18" pit, it offers the following features:

- A positive seal between ground box and base flange.
- Seal allows +/- 25 mm of vertical movement.
- Seal is replaceable without removal of pit valve.
- Nitrile seal which is compatible with aviation fuel (and all commonly used additives) water and air.
- Temperature range of -40deg C to +50deg C
- Sealing arrangement capable of withstanding a pressure of 1.25 bar (18psi) from beneath the ground box.
- Conforms to API and IP recommendations.

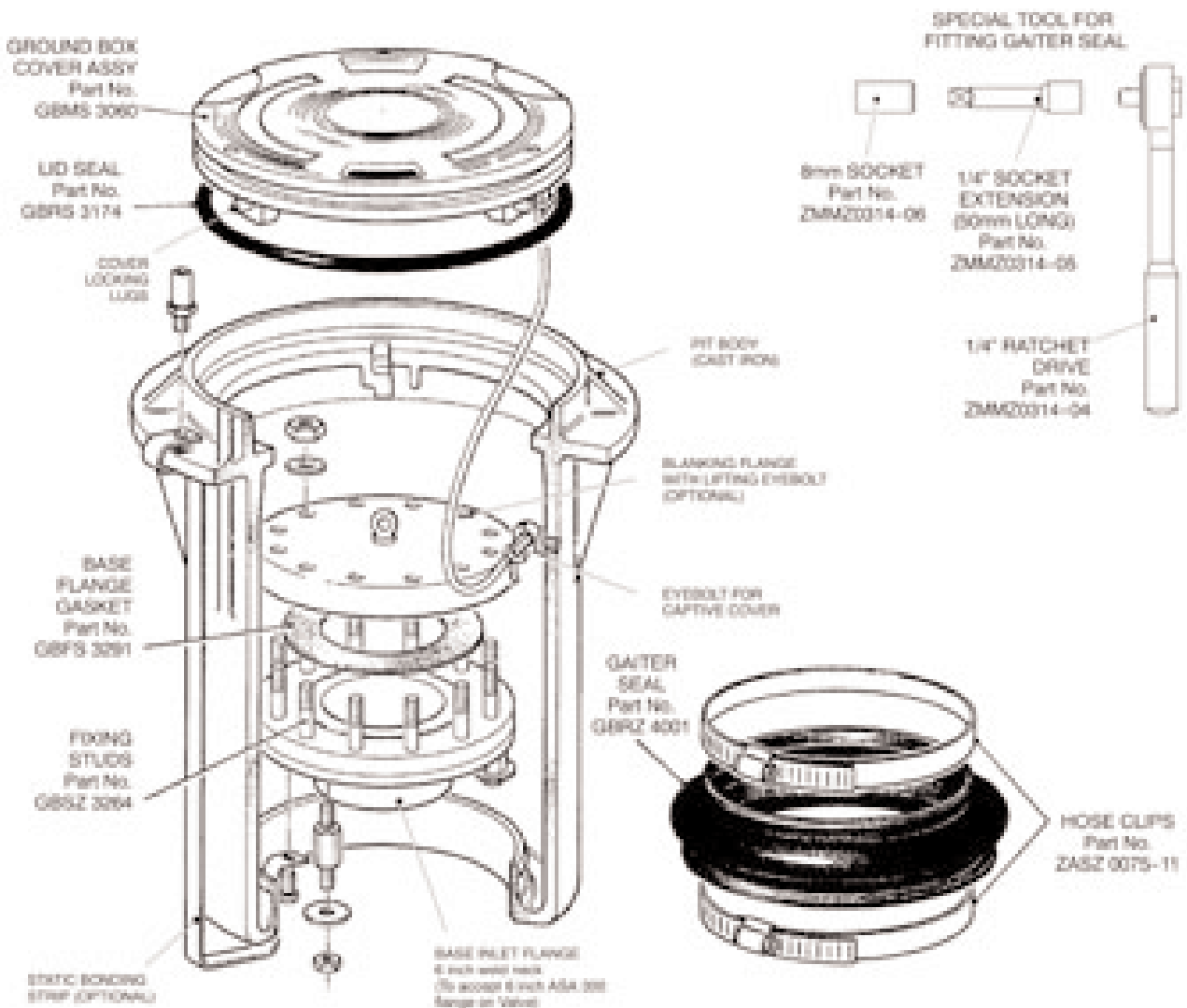
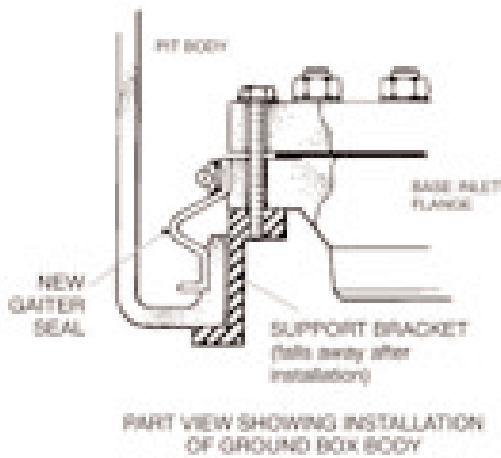

Ordering information

GBMY 4000	Ground box assembly
GBMY 4008	Base flange sub assembly
GBMY 4009	Bonding strip and grip kit
GBMY 3000	Blanking flange and gasket strip

Avery-Hardoll also offer a full range of pit valves for the above including the PV1000 and PV1100 series offering:-

MANUAL ON / LANYARD OFF

AIR ON / AIR OFF

AIR ON / AIR OFF WITH LANYARD OVERRIDE

See Data Sheet PRO CV 50 and PRO CV 55

Sampling, vent and drain valves are also available. **See data sheet PRO CV 80**

Avery-Hardoll
Holland Way
Blandford Forum
Dorset DT11 7BJ
UK

Tel: +44 (0) 1258 486600
Fax: +44 (0) 1258 486601

www.meggittfuelling.com

Whittaker Controls
12838 Saticoy St
North Hollywood
California 91605-3505
USA

Telephone: +1 818 765 8160
FAX: +1 818 759 2194

www.wkr.com
www.meggitt.com

MEGGITT