

Fuelling products

Measurement

Mechanical bulkmeters CM series

Mechanical bulkmeter CM series



Key Features

- Positive displacement liquid measuring instruments
- Free from installation effects
- Accuracy consistent between calibration levels
- Suitable for use in distribution depots and aviation refuelling vehicles
- Flow Rates of 22 igpm (100 lpm) to 880 igpm (4000 lpm)

CM SERIES METERS

Meggitt bulkmeters are precision made, positive displacement, liquid measuring instruments, which maintain accurate metering over long periods of operation. Simplicity of design and construction together with sustained accuracy make these meters ideally suited for use on aviation refuelling vehicles and in oil terminals.

Meggitt Control Systems

Our product competencies & services:
Aerospace valves | Thermal management solutions | Environmental control systems | Electro-mechanical products
Ground fuelling products | Energy products | Aftermarket services

MEGGITT
smart engineering for
extreme environments

Fuelling products

Measurement

Mechanical bulkmeters CM series

Specification

OPERATION

The positive displacement principle is the ONLY accurate method of measuring fluid flow. No other technology can achieve such accuracy because measurement becomes inferred, that is indirect and subject to assumption. The Meggitt bulkmeter directly converts volume to rotational output with minimum scope for error and with minimal disturbance from surrounding conditions, eg. turbulence from nearby valves, bends, etc.

The product enters the meter through the inlet manifold (1) and causes the rotor (4) to revolve by pressure on the vanes (3).

The proximity of the rotor (4) to the body (2) forms an efficient seal, whilst the profile of the casing ensures that the vanes (3) are guided through the measuring crescent (5), where the volume of product is accurately measured.

An extension shaft driving through a pressure tight gland in the meter front cover, transmits the rotor revolutions to the calibrating gearing (6) which drives the counter (7).

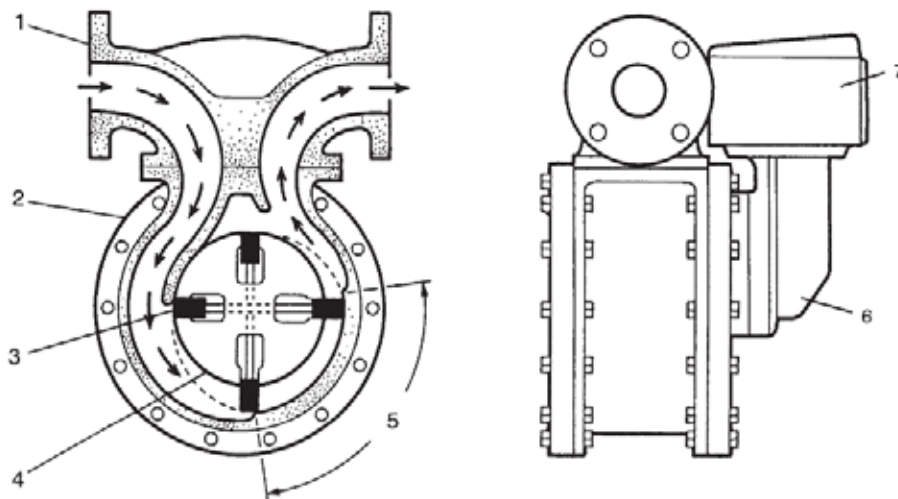

CONSTRUCTION

MANIFOLD:	Ductile iron (single/double capsule) Fabricated steel (all builds) Cast Aluminium (6" Triple only)
BODY:	Ni-Resist cast iron
VANES:	Carbon
ROTOR:	Aluminium or Ni-Resist cast iron
COVERS:	Carbon Steel
IBEARINGS:	Stainless steel
SEALS:	High nitrile or fluorocarbon

Meggitt Control Systems

Our product competencies & services:
Aerospace valves | Thermal management solutions | Environmental control systems | Electro-mechanical products
Ground fuelling products | Energy products | Aftermarket services

MEGGITT
smart engineering for
extreme environments

Fuelling products

Measurement

Mechanical bulkmeters CM series

Specification

PRESSURE LOSS

The low pressure drop for the CM series of Meggitt bulkmeters is shown on page 4.

VISCOUS PRODUCTS

Meggitt bulkmeters can be used on all petroleum products of all viscosities that are normally pumped. However there is obviously an increase in pressure drop with more viscous fuels which will, under normal circumstances, limit the maximum flowrate obtainable.

It is recommended that the pressure drop through a bulkmeter should not exceed 15 psi (1 bar), above which the load on the bearings will start to cause wear. Consequently when using products with viscosities (at operating conditions) above 100 centistokes, it is necessary to reduce the maximum permitted flowrate. As a guide it is suggested that the pressure drop through the meter should not exceed 10 psi (0.7 bar) for continuous running at maximum speed or 15 psi (1 bar) for continuous running at half speed.

METER ACCESSORIES

A full range of accessories is available for use with all Meggitt bulkmeters and these are described in the following paragraphs. Details may be obtained from each relevant leaflet.

COUNTERS

The meters are fitted with standard Veeder-Root counters, having a five large figure zeroising drum and a seven figure small non-zeroising totaliser and can be supplied to read in any of the following units:

Imperial gallons	US gallons	Cubic metres
Litres	Decalitres	

MASTERLOAD

Electronic calibration, display and control system suitable for both depot and vehicle applications.

TICKET PRINTER

Available with or without identifier, in the following forms:

1. Batch delivery, starting at zero and showing the amount delivered.
2. Accumulative tote giving initial and final totaliser figures.

MECHANICAL PRESET AND PRESET VALVE

A Veeder-Root preset register with 5 figure resettable counter is used to preset a batch to be delivered. This controls a lever operated preset valve via a mechanical linkage, providing two stage closure and precise shut off of flow.

MECHANICAL PRESET WITH MICROSWITCHES

Microswitches can be fitted to the preset register to control pump start and stop, and solenoid operated preset valves.

RATE OF FLOW INDICATOR

SWIVEL

Meggitt Control Systems

Our product competencies & services:
Aerospace valves | Thermal management solutions | Environmental control systems | Electro-mechanical products
Ground fuelling products | Energy products | Aftermarket services

MEGGITT
smart engineering for
extreme environments

Fuelling products

Measurement

Mechanical bulkmeters CM series

Specification

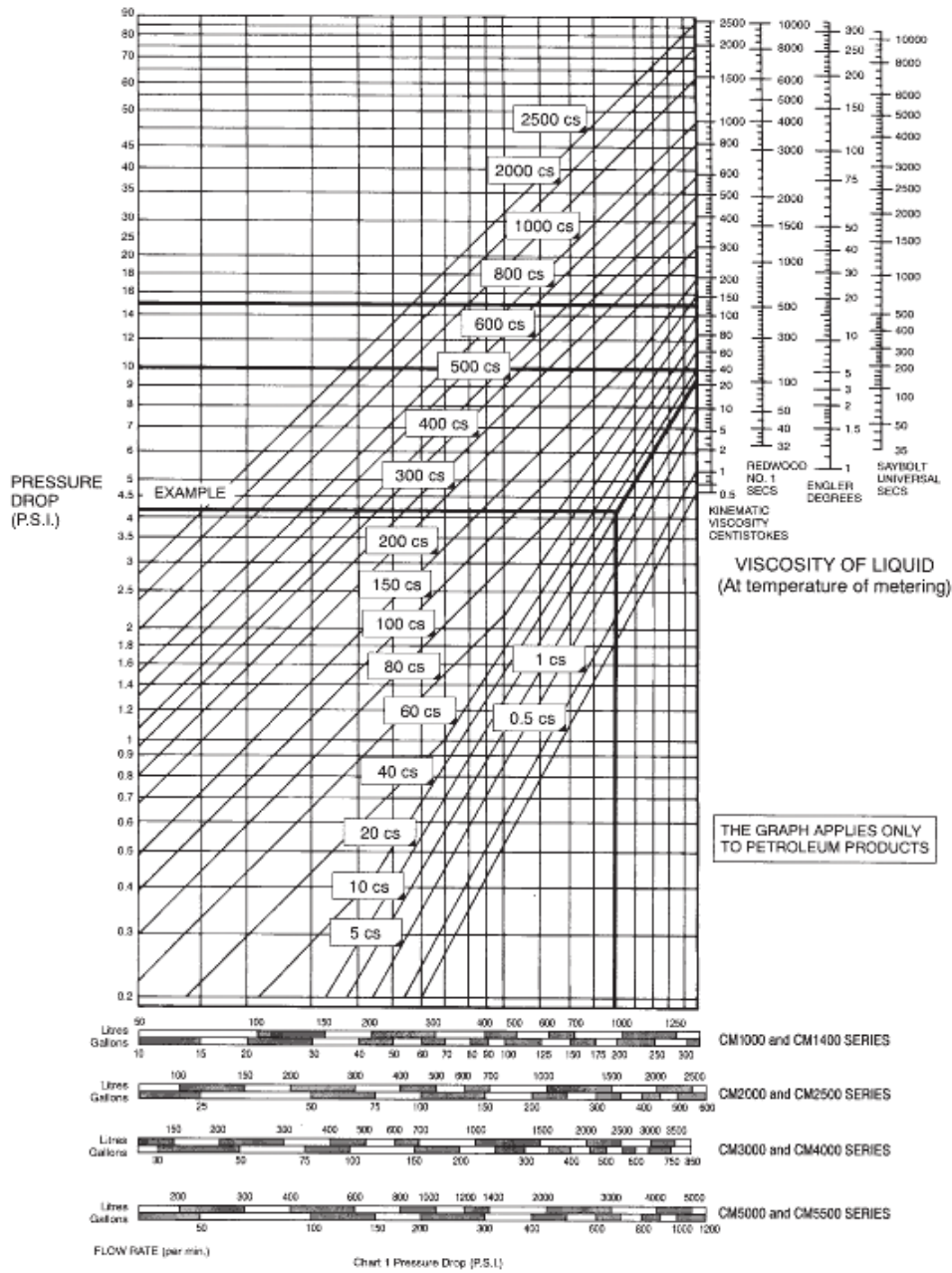

Meggitt Control Systems

Our product competencies & services:
Aerospace valves | Thermal management solutions | Environmental control systems | Electro-mechanical products
Ground fuelling products | Energy products | Aftermarket services

MEGGITT
smart engineering for
extreme environments

Fuelling products

Measurement

Mechanical bulkmeters CM series

Specification

Maximum working pressure:	10.5 bar (150 psi)
Test pressure:	21 bar (300 psi)
Temperature range:	-28°C to 100°C
Volume per revolution:	2.27 litres (single capsule) 4.54 litres (double capsule) 6.82 litres (triple capsule) 9.08 litres (4 capsule)
Repeatability typically:	.02%

Typical accuracy curves for basic meter build (10:1 turndown)

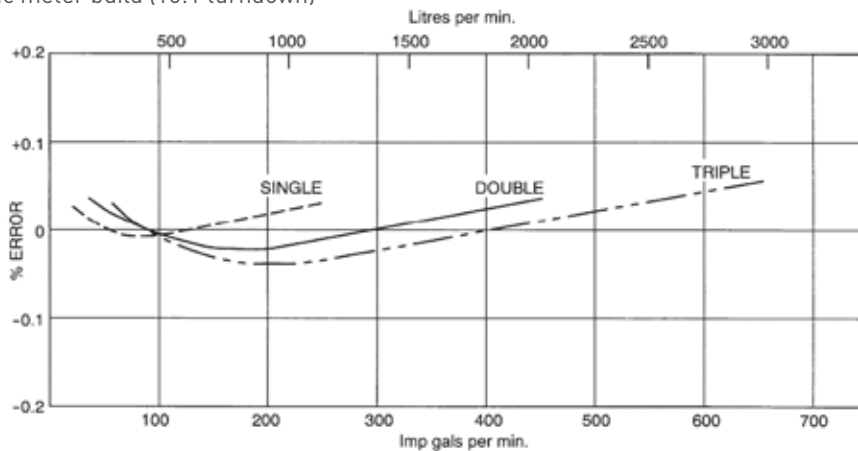

CALIBRATION

Calibration adjustment is provided to minimize the meter error at any selected flowrate. Adjustment is stepless; no gear changing is necessary; and the calibration screw is easily accessible after breaking a seal and removing a sealing screw.

All meters are tested to 300 psi (21 bar).

All Meggitt meters are tested before despatch at a range of flowrates and test certificates can be supplied if requested.

The fluid used for testing is odorless kerosene.

Specific gravity at 60/60°F, 15/15°C = 0.8

Viscosity at 60°F, 15°C = 2.4 centistokes.

Suggested correction to be made to the calibrating mechanism when used with products with different viscosities as follows:

Gasoline	+ 0.1%	+ means increase counter readings
Kerosene	0.0%	- means decrease counter readings
Gas Oil	- 0.1%	
Fuel Oil	- 0.22%	

Meggitt Control Systems

Our product competencies & services:
Aerospace valves | Thermal management solutions | Environmental control systems | Electro-mechanical products
Ground fuelling products | Energy products | Aftermarket services

MEGGITT
smart engineering for
extreme environments

Fuelling products

Measurement

Mechanical bulkmeters CM series

Specification

CM series

Flow range

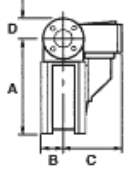
SINGLE CAPSULE METER 	METER SERIES	PIPELINE SIZE	FLOW RATE			FLANGES	
			Imp Gall	Lpm	m ³ /hr	Conform to	Material
			CM 1000	2 1/2" (63mm)	22 to 220	100 to 1000	6 to 60
CM 1400	3" (76mm)	31 to 310	140 to 1400	8 to 84	ASA 125 FF	DUCTILE IRON	
			320	1450	87	intermittent use	

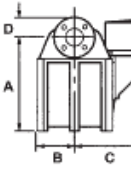
DOUBLE CAPSULE METER 	METER SERIES	PIPELINE SIZE	FLOW RATE			FLANGES	
			Imp Gall	Lpm	m ³ /hr	Conform to	Material
			CM 2000	3" (76mm)	44 to 440	200 to 2000	12 to 120
CM 2500	4" (102mm)	55 to 550	250 to 2500	15 to 150	ASA 125 FF ASA 150 RF	DUCTILE IRON	
			615	2800	168	intermittent use	

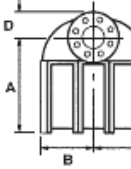
TRIPLE CAPSULE METER 	METER SERIES	PIPELINE SIZE	FLOW RATE			FLANGES	
			Imp Gall	Lpm	m ³ /hr	Conform to	Material
			CM 3000	4" (102mm)	65 to 650	300 to 3000	18 to 177
CM 4000	6" (152mm)	88 to 880	400 to 4000	24 to 240	ASA 150 FF	ALUMINIUM	
			935	4250	255	intermittent use	

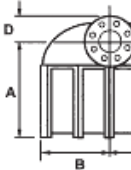
4 CAPSULE METER 	METER SERIES	PIPELINE SIZE	FLOW RATE			FLANGES	
			Imp Gall	Lpm	m ³ /hr	Conform to	Material
			CM 5000	6" (152mm)	110 to 1100	500 to 5000	30 to 300
CM 5500	8" (203mm)	120 to 1200	550 to 5500	33 to 330	ASA 150 FF ASA 150RF	STEEL	

NOTE:

All steel manifolds are available with raised face and 300lb flanges and dimensions.

Meggitt Control Systems

Our product competencies & services:
Aerospace valves | Thermal management solutions | Environmental control systems | Electro-mechanical products
Ground fuelling products | Energy products | Aftermarket services

MEGGITT
smart engineering for
extreme environments

Fuelling products

Measurement

Mechanical bulkmeters CM series

Specification

FLANGE BOLT HOLES			DIMENSION BETWEEN FLANGE FACES		METER DIMENSIONS								APPROX. WEIGHT OF BASIC METER	
No. Off	SIZE		mm	ins	A		B		C		D		kg	lbs
	mm	ins			mm	ins	mm	ins	mm	ins				
4	19	0.75	356	14	410	16.1	91	3.6	285	11.2	89	3.5	82	181
4	19	0.75	356	14	410	16.1	91	3.6	285	11.2	95	3.75	82	181

FLANGE BOLT HOLES			DIMENSION BETWEEN FLANGE FACES		METER DIMENSIONS								APPROX. WEIGHT OF BASIC METER	
No. Off	SIZE		mm	ins	A		B		C		D		kg	lbs
	mm	ins			mm	ins	mm	ins	mm	ins				
4	19	0.75	400	15.75	407	16.0	155	6.1	348	13.7	95	3.75	100	220
8	19	0.75	400	15.75	420	16.5	155	6.1	348	13.7	115	4.5	103	227

FLANGE BOLT HOLES			DIMENSION BETWEEN FLANGE FACES		METER DIMENSIONS								APPROX. WEIGHT OF BASIC METER	
No. Off	SIZE		mm	ins	A		B		C		D		kg	lbs
	mm	ins			mm	ins	mm	ins	mm	ins				
8	19	0.75	400	15.75	430	16.9	218	8.6	411	16.2	115	4.5	121	267
8	22	0.875	400	15.75	430	16.9	218	8.6	411	16.2	140	5.5	106	233

FLANGE BOLT HOLES			DIMENSION BETWEEN FLANGE FACES		METER DIMENSIONS								APPROX. WEIGHT OF BASIC METER	
No. Off	SIZE		mm	ins	A		B		C		D		kg	lbs
	mm	ins			mm	ins	mm	ins	mm	ins				
8	22	0.875	400	15.75	450	17.7	300	11.8	495	19.5	140	5.5	163	358
8	22	0.875	400	15.75	450	17.7	300	11.8	495	19.5	171	6.75	164	360

Meggitt Control Systems

Our product competencies & services:
 Aerospace valves | Thermal management solutions | Environmental control systems | Electro-mechanical products
 Ground fuelling products | Energy products | Aftermarket services

MEGGITT
 smart engineering for
 extreme environments

Fuelling products

Measurement

Mechanical bulkmeters CM series

Key Dimensions

EXTENDED COUNTER DRIVE

Provided for installations where the counter is required to be read at height above the bulkmeter.

VERTICAL MOUNTING

All sizes of Meggitt CM series bulkmeters can be supplied with counters and counter extensions arranged so that the meters can be mounted in vertical pipework.

STRAINER

Essential to prevent damage to the meter and is available with 40, 60, 80, 100 and 120 mesh baskets, with either cast iron or cast steel body.

AIR SEPARATOR

Prevents entrained air reaching the meter.

FLOW GOVERNOR

Limits flow rate at maximum meter capacity when several meters are fed from one pump.

Contact

Meggitt North Hollywood

12838 Saticoy Street
North Hollywood
California 91605-3505
USA

Tel: (818) 765-8160
Fax: (818) 759-2194
www.meggitt.com

Meggitt Control Systems

Our product competencies & services:

Aerospace valves | Thermal management solutions | Environmental control systems | Electro-mechanical products
Ground fuelling products | Energy products | Aftermarket services

MEGGITT
smart engineering for
extreme environments