

Meggitt Fuelling Products

Avery-Hardoll Whittaker Controls

HYDRANT SHUTOFF VALVE F352 AND F353

Features

- Fully complies to third edition of the AP/IP 1584 requirements
- ANSI 150 lb. rated flange mates six-inch ANSI 300 lbs. flange (F352)
- Portions of valve are maintainable in PIT with valve under pressure
- Air deadman pilot control available
- Four mesh stone guard standard
- 20 mesh internal strainer optional
- Four-inch API outlet
- Six position product selection
- Fits in 18-inch diameter pit
- Available with dual pilot shutoff as a modification
- Unit meets NFPA 407 requirements

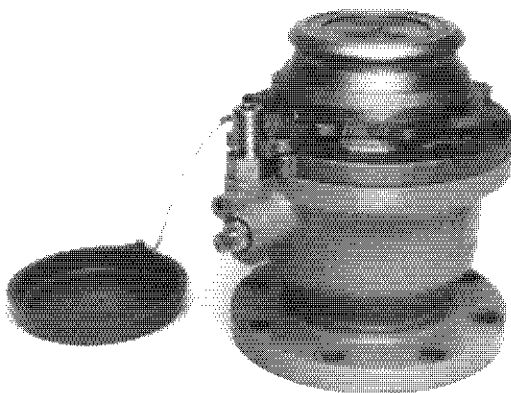

F352 Hydrant shutoff valve

The Whittaker F352 hydrant shutoff valve is a lanyard operated six-inch by four-inch shutoff valve designed, tested, and found to fully comply with the requirements of the IP standard for aviation hydrant pit systems "Recommended Arrangements for New Facilities" dated April 1980. The Whittaker F353 hydrant shutoff valve is similar to the F352 except it has a 4 inch ASA inlet flange and is nearly four-inches shorter.

The F352/F353 hydrants are provided with both an automatic and a manual means of closing off the main chamber to allow removal and maintenance of the servo assembly and strainer while the main valve is still under pressure. See note below.

Ordering data

The basic F352 and F353 hydrant valves are lanyard operated shutoff valves with API, four-inch outlets. Inlets mate six and four-inch ANSI flanges respectively. The F352 includes a four mesh stoneguard as standard equipment. Both units are available with various modifications.

Note! Under hydrant should always be turned off prior to any maintenance.

See the modification section of this catalog for various options to the part number listed above.

Contact your local Whittaker distributor or Whittaker directly for technical information beyond that listed in the technical section of this catalog.

Operating characteristics

- Max. operating pressure - 200 PSI (13.8 BAR)
- Opening time - 5 to 10 seconds
- Closing time - adjustable from two to five seconds (factory set at five seconds)
- Pressure drop -
F352 - 14.5 PSI (1.00 BAR) at 4500 1/min. (1189USGM)
F353 - 12 PSI (0.83 BAR) at 4500 1/min (1189 USGPM)
- Weight -
F352 - 40Kg (88 lbs)
F353 - 27.51g (60 lbs)
- Peak surge pressure -
F352 - 305 PSI (21 BAR)
F353 - 305 PSI (21 BAR)

Mating components

Both the F352 and F353 are designed to be used with API hydrant couplers.

The Whittaker couplers conforming to this requirement are as follows:

- F239 Hydrant coupler with deadman control and/or pressure control
- F240 or F250 Hydrant coupler

Note! Opening and closing time may vary slightly with inlet pressure.

MEGGITT

HYDRANT SHUTOFF VALVE F352 AND F353

F352 Dimensions

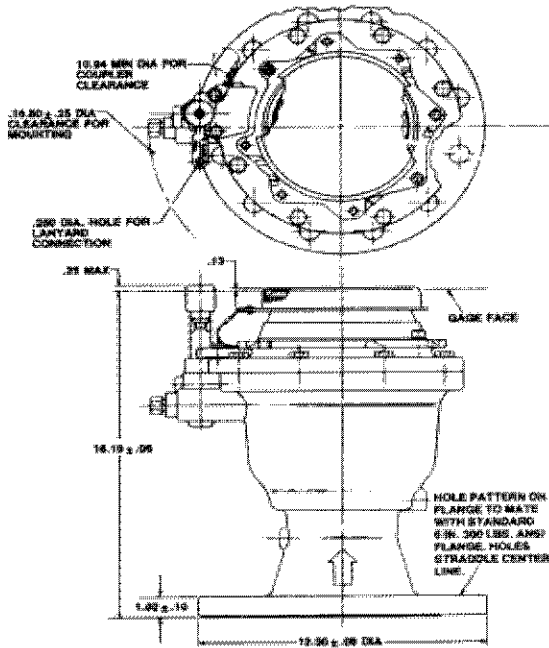

F353 Dimensions

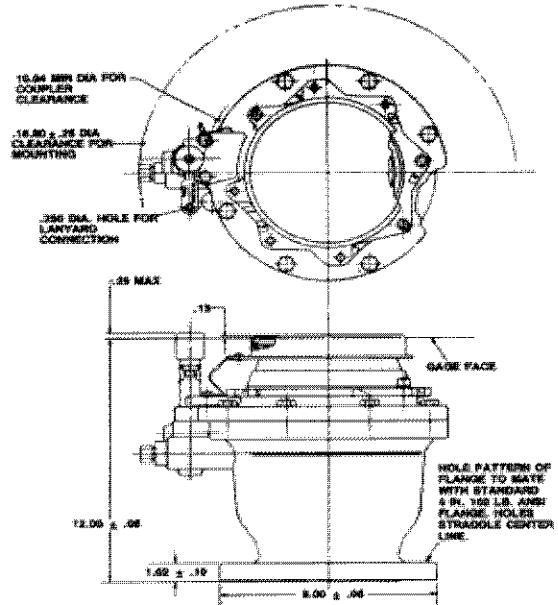

Hydrant Coupler Installation

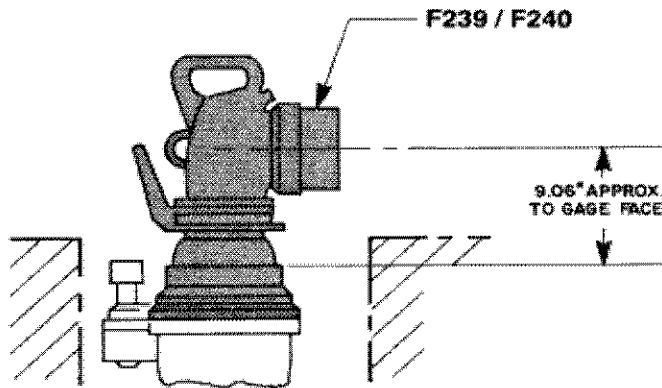

Avery-Hardoll
Holland Way
Blandford Forum
Dorset DT11 7BJ
UK

Tel: +44 (0) 1258 486600
Fax: +44 (0) 1258 486601

www.meggittfuelling.com

Whittaker Controls
12838 Saticoy St
North Hollywood
California 91605-3505
USA

Telephone: +1 818 765 8160
FAX: +1 818 759 2194

www.wkr.com
www.meggitt.com

MEGGITT