

Meggitt Fuelling Products

Avery-Hardoll Whittaker Controls

NONPRESSURE CONTROL COUPLER F250 - FOUR-INCH API

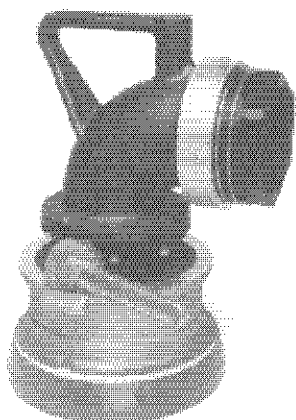

The Whittaker F250 hydrant coupler is designed to connect to four-inch hydrants and adaptors manufactured in accordance to API bulletin 1584. Optional outlet configurations allow the use of various types of threads and hose sizes. (Supersedes F203, F230, F240 series hydrant couplers.)

At the split line of the elbow and the main body a four-inch TTMA flange configuration allows the unit to have an adapter attached so the unit can be used as a straight connection without the elbow. A separate boss is on the elbow casting which will allow a fuel sampler or pressure tap to be installed. This boss is standard. However, the drilling and tapping are an option.

Features

- Full size four-inch flow path
- Optional outlets for use with 2.5, three or four-inch NPT or BSP and four-inch ASPT threaded hose
- Optional six position product selection
- Floating nose seal design which can be replaced with pressure in hose
- Operating handle with full interlock feature - will not open unless locked onto the hydrant or adaptor, may not be disconnected unless closed
- Three-piece coupler - elbow-swivel design for ease of maintenance
- Four-inch disconnect type swivel with safety lock rings for ease of removal from hose
- Mates Whittaker hydrants F368, F352, and F353 and adapter F414 and competitive hydrants and adapters designed in accordance with API bulletin 1584
- Texin bumper reduces coupler wear
- Pressure drop F250 with F368 hydrant - 13.0 PSI at 1200 GPM
- Operating pressure - 0 to 200 PSI (13.9 BAR)
- Peak surge pressure 305 PSI (21.0 BAR)
- Does not require a separate lock for the shroud

See the modification section of this catalog for various options to the part number listed above.

Contact your local Whittaker distributor or Whittaker directly for technical information beyond that listed in the technical section of this catalog.

MEGGITT

NONPRESSURE CONTROL COUPLER F250 - FOUR-INCH API

F250 Dimensions

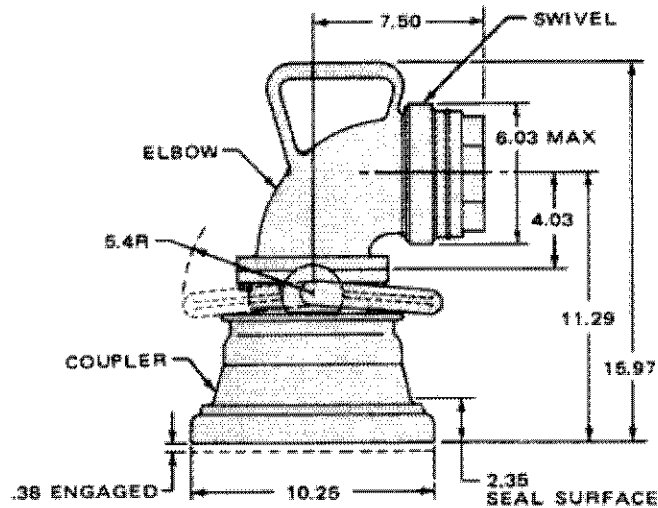

F250 Flow Data

Notes:
Data shown is for inlet to outlet of hydrant and coupler combination shown.

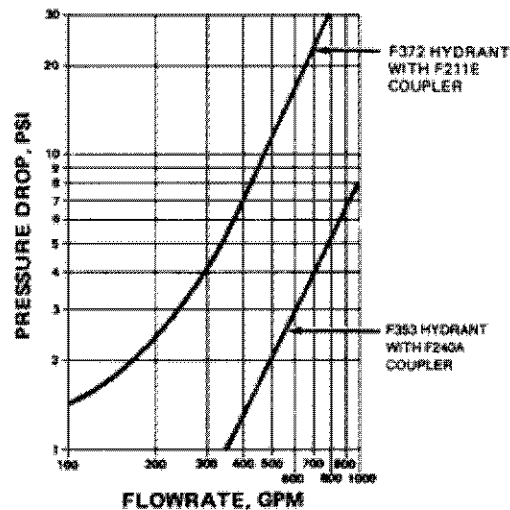

Avery-Hardoll
Holland Way
Blandford Forum
Dorset DT11 7BJ
UK

Whittaker Controls
12838 Saticoy St
North Hollywood
California 91605-3505
USA

Tel: +44 (0) 1258 486600
Fax: +44 (0) 1258 486601

Telephone: +1 818 765 8160
FAX: +1 818 759 2194

www.meggittfuelling.com

www.wkr.com
www.meggitt.com

MEGGITT