

PRODUCTS - Couplings

2.5 inch Aviation Tank Unit
 FCMY 107M5L & 108M5L - Low Pressure Coupling
 FCMY 107M5H & 108M5H - High Pressure Coupling
 SEALING CAP, FCMY122M2



Introduction

The FCMY107M5 & 108M5 Series Aviation Tank Units are designed for use in aviation refuelling systems with a maximum working pressure of 10.2 bar (150 psi), in conjunction with 2 1/2" bayonet type aviation hose units.

The Mk5 version can be identified by its unplated adaptor, separate aluminium valve seating and one piece valve head. The suffix 'L' in the unit part number indicates that the unit is suitable for use where the coupling pressure does not exceed 5.5 bar (80 psi). Units with the suffix 'H' have a pressure equalising valve to facilitate coupling on systems where the coupling pressure exceeds 5.5 bar (80 psi).

The FCMY122M2 sealing cap should be used to prevent the ingress of dirt or water. It seals by means of a dual 'O'ring spring-loaded plate.

The Mk2 version can be identified by the three integral lugs which have replaced the roller assemblies.

Specification

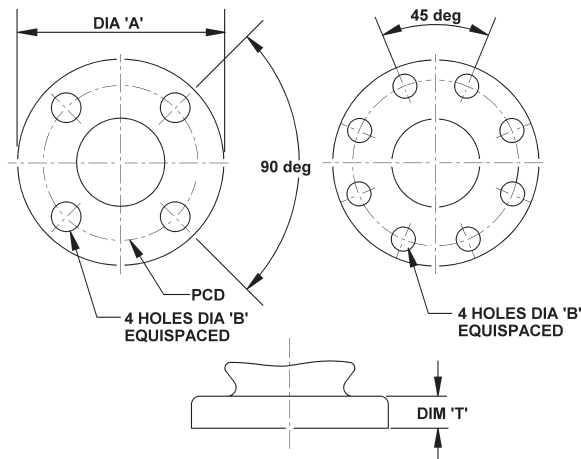

Flanged version

PART NUMBER	Flange Type	Selectivity	No. of Holes	' A' Dia	' B' Dia	PCD	Dim 'T'
FCMY107M5L	3'' ASA150	N/S	4	7.5	0.75	6	0.875
FCMY107M5H	3'' ASA150	N/S	4	7.5	0.75	6	0.875
FCMY107M5L/S1-S3	3'' ASA150	S1-S3	4	7.5	0.75	6	0.875
FCMY107M5H/S1-S3	3'' ASA150	S1-S3	4	7.5	0.75	6	0.875
FCMY107M5L/S4-S5	3'' ASA150	S4-S5	4	7.5	0.75	6	0.875
FCMY107M5H/S4-S5	3'' ASA150	S4-S5	4	7.5	0.75	6	0.875
FCMY107M5LA	2.5'' ASA150	N/S	4	7	0.75	5.5	0.875
FCMY107M5HA	2.5'' SA150	N/S	4	7	0.75	5.5	0.875
FCMY107M5LA/S1-S3	2.5'' ASA150	S1-S3	4	7	0.75	5.5	0.875
FCMY107M5HA/S1-S3	2.5'' ASA150	S1-S3	4	7	0.75	5.5	0.875
FCMY107M5LA/S4-S5	2.5'' ASA150	S4-S5	4	7	0.75	5.5	0.875
FCMY107M5HA/S4-S5	2.5'' ASA150	S4-S5	4	7	0.75	5.5	0.875
FCMY107M5LB	3'' TTMA	N/S	8	5.625	0.437	4.875	0.5
FCMY107M5HB	3'' TTMA	N/S	8	5.625	0.437	4.875	0.5
FCMY107M5LB/S1-S3	3'' TTMA	S1-S3	8	5.625	0.437	4.875	0.5
FCMY107M5HB/S1-S3	3'' TTMA	S1-S3	8	5.625	0.437	4.875	0.5
FCMY107M5LB/S4-S5	3'' TTMA	S4-S5	8	5.625	0.437	4.875	0.5
FCMY107M5HB/S4-S5	3'' TTMA	S4-S5	8	5.625	0.437	4.875	0.5
FCMY107M5LC	65mm(2.5)DIN	N/S	8	154mm	11mm	130mm	0.5
FCMY107M5HC	65mm(2.5)DIN	N/S	8	154mm	11mm	130mm	0.5
FCMY107M5LC/S1-S3	65mm(2.5)DIN	S1-S3	8	154mm	11mm	130mm	0.5
FCMY107M5HC/S1-S3	65mm(2.5)DIN	S1-S3	8	154mm	11mm	130mm	0.5
FCMY107M5LC/S4-S5	65mm(2.5)DIN	S4-S5	8	154mm	11mm	130mm	0.5
FCMY107M5HC/S4-S5	65mm(2.5)DIN	S4-S5	8	154mm	11mm	130mm	0.5

PART NUMBER	Thread Type	Selectivity
FCMY108M5L	2.5'' BSP	N/S
FCMY108M5H	2.5'' BSP	N/S
FCMY108M5L/S1-S3	2.5'' BSP	S1-S3
FCMY108M5H/S1-S3	2.5'' BSP	S1-S3
FCMY108M5L/S4-S5	2.5'' BSP	S4-S5
FCMY108M5H/S4-S5	2.5'' BSP	S4-S5
FCMY108M5LN	2.5'' NPT	N/S
FCMY108M5HN	2.5'' NPT	N/S
FCMY108M5LN/S1-S3	2.5'' NPT	S1-S3
FCMY108M5HN/S1-S3	2.5'' NPT	S1-S3
FCMY108M5LN/S4-S5	2.5'' NPT	S4-S5
FCMY108M5HN/S4-S5	2.5'' NPT	S4-S5

Threaded version

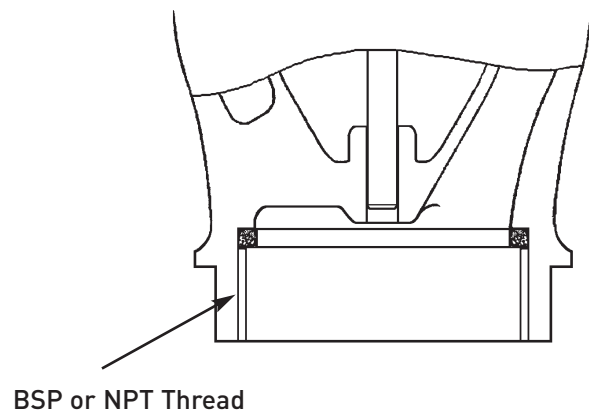

BSP or NPT Thread

All internal components are common for both FCMY107M2 and FCMY108M2 versions

Aviation Tank Unit FCMY 107M5L - Low Pressure Coupling

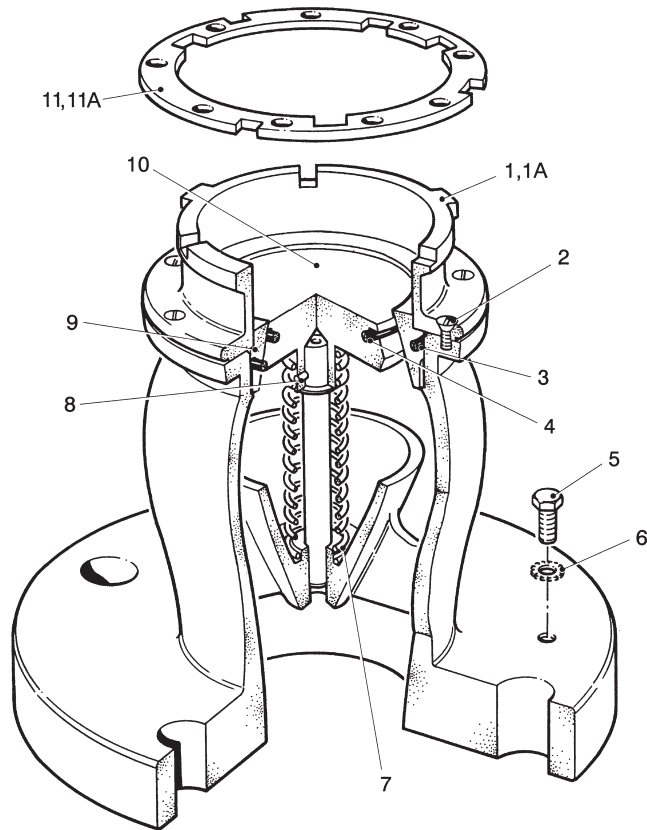

ITEM	PART No.	DESCRIPTION	Qty
1	FCCZ 1454	TANK UNIT ADAPTOR-NON SELECTIVE	1
1A	FCCZ 1455	TANK UNIT ADAPTOR-SELECTIVE	1
2	ZS4001A0208A	SCREW, 2BA x 11/2" LONG CSK. HD., ST. STL.	19
3	ZO32M079530A	`O' RING	1
4	ZAXX0099-1	`O' RING	1
5	ZS2228A0206A	SCREW 2BA	1
6	ZW8206A02A	WASHER 2BA INTERNAL SHAKE PROOF	1
7	ZASZ0001-21	SPRING	1
8	ZT4001E0414A	TENSION PIN 1/8" DIAMETER	1
9	FCSZ 1453	VALVE HEAD SEATING	1
10	FCMS 1460	VALVE HEAD ASSY, LOW PRESSURE	1
11	FCSZ 1412	SETTING RING, POSITIONS 1 TO 3	1
11A	FCSZ 1413	SETTING RING, POSITIONS 4 & 5	1

Aviation Tank Unit FCMY 107M5H - High Pressure Coupling

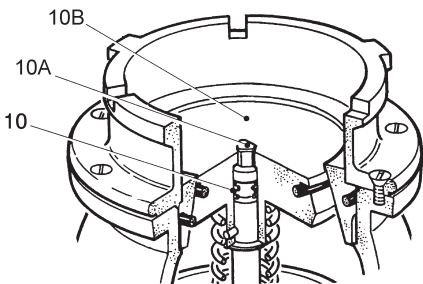

ITEM	PART No.	DESCRIPTION	Qty
ITEMS 1-9 AS LOW PRESSURE COUPLING (SEE TABLE ABOVE)			
10	FCSZ 1402	SPRING	1
10A	FCMZ 1396	PIP VALVE SUB-ASSEMBLY	1
10B	FCMS 1459	VALVE HEAD ASSY, HIGH PRESSURE	1
ITEMS 11, 11A AS LOW PRESSURE COUPLING (SEE TABLE ABOVE)			

Maintenance

Inspect the unit at weekly intervals for the following:-

- Evidence of leakage
- Cleanliness and corrosion
- Bayonet Lugs,
 1. Wear to be checked using Wear Gauge, Pt No. TASS5050, (Min. thickness, 5.97 mm (0.235in)
 2. Distortion or bending not to exceed 0.4mm (0.015in).
- Condition of setting ring slots (if used)
- Serviceability of cap
- Security of fastenings

MAXIMUM TEST PRESSURE, 15.3 bar (225 psi)
SAFE WORKING PRESSURE, 10.2 bar (150 psi).

Spare Parts

When ordering spare parts, please quote the following:-

- UNIT PART NUMBER
- ITEM PART NUMBER
- FULL DESCRIPTION
- PUBLICATION NUMBER

Sealing Cap FCMY 122M2

ITEM	PART No.	DESCRIPTION	Qty
12	ZASZ0058-35	EXTERNAL CIRCLIP	1
34	ZARZ0041-62	'O' RING	2
5	FCSZ 206	SPRING	1
	ZAMZ 0079-1	CHAIN / KEY RINGS	1
	HUSZ 4340	CAP PLATE	1

NOTE:-
ONLY THOSE ITEMS LISTED ARE AVAILABLE AS SPARES

Avery-Hardoll
Holland Way
Blandford Forum
Dorset DT11 7BJ
UK

Whittaker Controls
12838 Saticoy St
North Hollywood
California 91605-3505
USA

Tel: +44 (0) 1258 486600
Fax: +44 (0) 1258 486601

Tel: +1 818 765 8160
Fax: +1 818 759 2194

www.meggittfuelling.com

www.wkr.com
meggitt.com

Selectivity

Selective units are fitted with setting rings. These have slots cut into them to match up with the corresponding pins on the selective sleeve on the hose unit. Care must be taken when reassembling such units to ensure that the ring is returned to its original position.

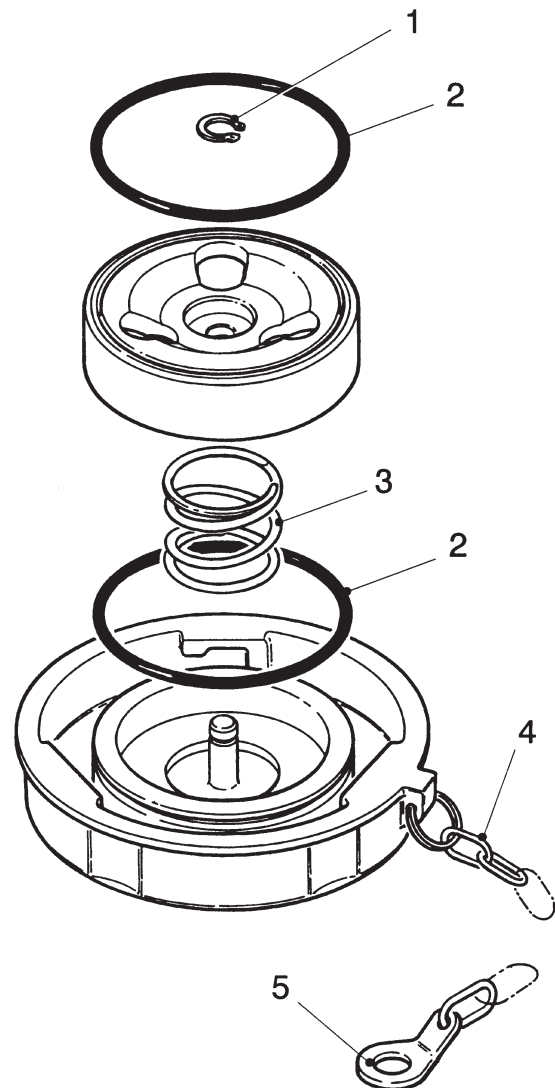

MEGGITT