

LNG LOADING ARM



FEATURES

- * LNG application
- * Safe bottom loading / -unloading
- * Reliable
- * Easy handling
- * Low maintenance
- * Economic
- * Environmentally friendly
- * EMCO high performance LNG swivel joints

This type of loading arm is especially designed to load LNG products. It is suitable for the bottom loading / unloading of road or rail tankers. The loading arm has a long reach and is suitable for applications where tanker connection flange cannot be accurately positioned.

Because of the robust and high quality design of the swivel joints and the precise loading arm balancing handling of the loading arm is very convenient.

The design of the stainless steel swivel joints are based on the reliable design of the D2000 and are also equipped with an interchangeable bearing module. The primary and the secondary product seal enable the operator to monitor the leakage during the whole operating time of the loading arm. In addition to that the ball raceway can be purged with dry gas and the swivel joints are designed to meet the requirements of the OCIMF.

LNG LOADING ARM

LNG LOADING ARM

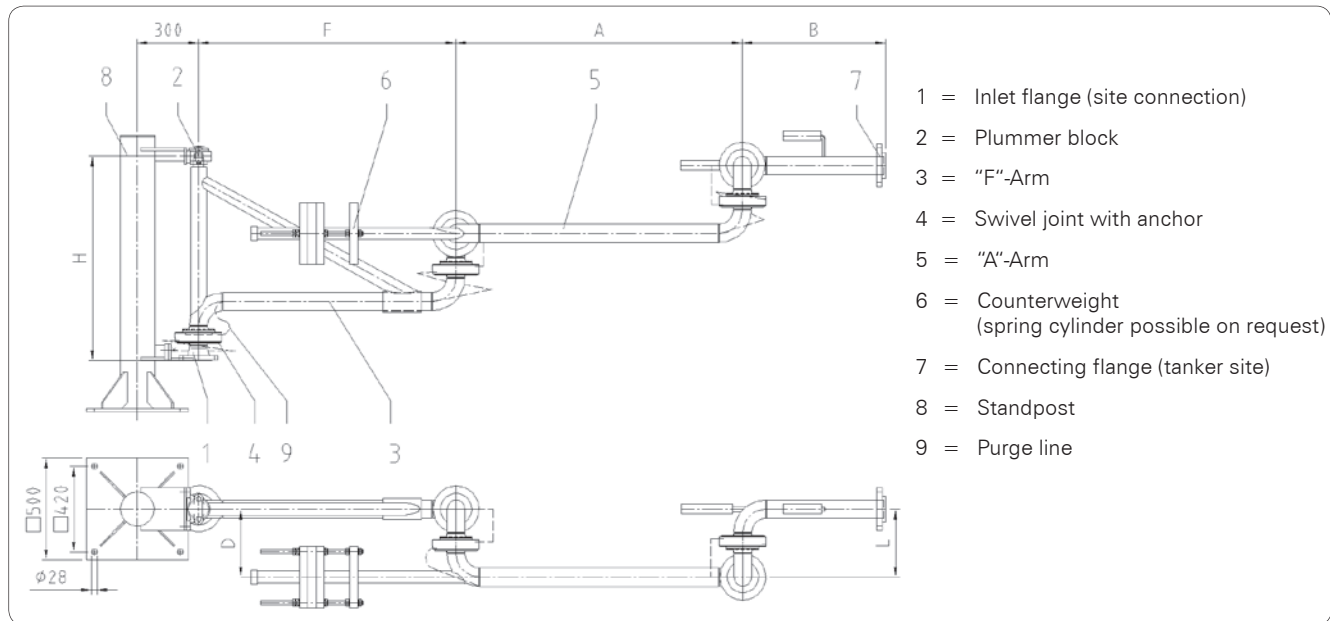

DIMENSIONS

DN	A*	B*	D	F*	L	Q DIN PN 16	Q ANSI 150 lbs
	mm	mm	mm	mm	mm	mm	mm
80	1400	700	333	1300	333	269	288
100	1400	700	411	1300	411	311	335

* Standard dimensions – Alternative dimensions available on request.

MATERIALS AND TECHNICAL DATA

Materials of product carrying parts and swivel joints	Stainless steel
Materials of seals	Fluroloy-G
Balancing method	Counter weights / spring cylinder
Sizes	DN 80, DN 100
Design pressure	max. 20 bar
Design temperature	-170 °C to + 80 °C

To be equipped with: Relief line or purge line. Flange connection detection system



ACCESSORIES

- * LNG shut-off valve
- * leakage control line of swivel joints
- * emergency release system

EMCOWHEATON

A Gardner Denver Product

Better by Design



EMCO WHEATON GmbH
 Emcostraße 2-4 · 35274 Kirchhain · Germany
 Phone +49 6422 84-0 · Fax +49 6422 5100
 www.emcowheaton.com · info-de@emcowheaton.com