

E2852 | BOTTOM HOSE LOADING STATION



Bottom hose loading station with unrestricted cross over and extended working envelope. EMCO WHEATON bottom loading is efficient loading of tank trucks.



FEATURES

- * Simultaneous loading of 5 different products
- * Total flexibility
- * Unrestricted crossover
- * Time saving
- * Petroleum applications
- * Over 40 years experience in the field of fluid handling equipment
- * Long working life
- * Reliable and well proven components:
 - * EMCO carbon steel swivel joint
 - * EMCO spring cylinder
 - * Robust rubber hose
 - * EMCO API dry break coupler
- * Safe working, easy operation and maintenance
- * Minimal spillage
- * Adequate space between loading arms and tank truck during filling
- * Free access for operation and escape way
- * Individual, customer designed units
- * Special materials are available, e.g. stainless steel

E2852

E2852 | BOTTOM HOSE LOADING STATION

DIMENSIONS AND TECHNICAL DATA

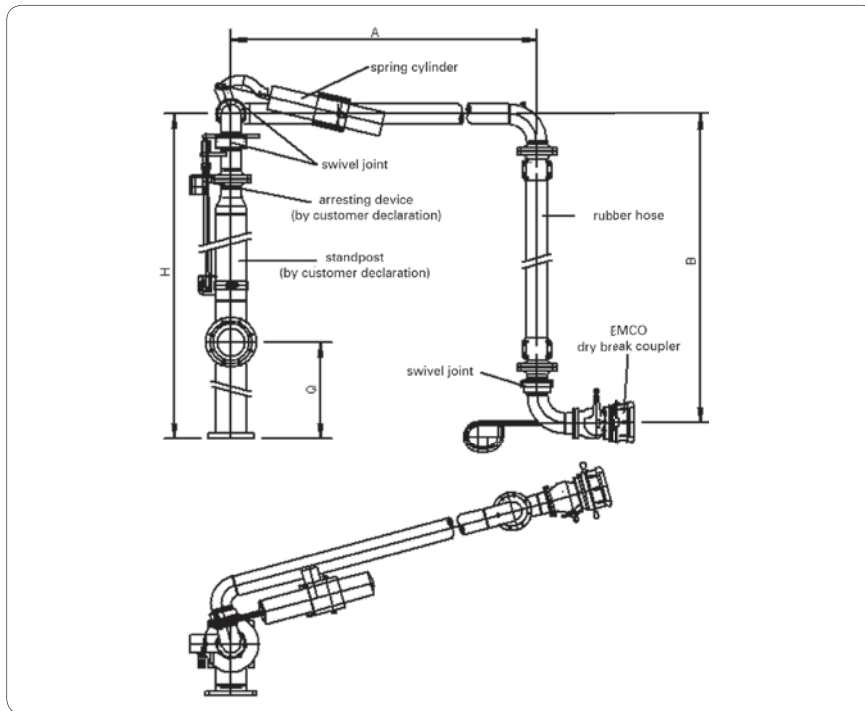

API coupler
For more details see our data sheet API couplers K2 and K2P.

MATERIALS AND TECHNICAL DATA

E2852	A mm	B mm	H* mm	Q mm	Design	Weight kg
-001	1700	2323	3100	by customer	left	310
-002	1900	2723	3500		left	340
-003	1900	3123	3900		left	360
-004	2100	3523	4300		right	400
-005	2100	3923	4700		left	430

* Based on size of foundation

ENVELOPE DRAWING

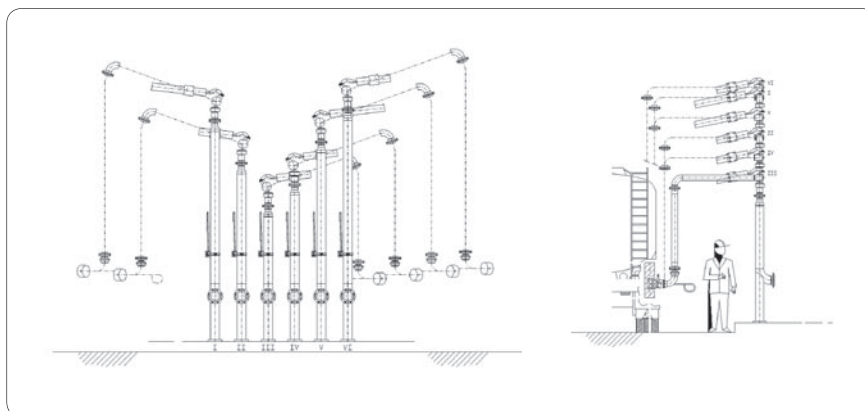

EMCO WHEATON carbon steel swivel joint with flame hardened ball race way for a long life time!

For more details see our data sheet swivel joint **D2000**.

EMCOWHEATON

A Gardner Denver Product

Better by
Design



EMCO WHEATON GmbH
Emcostraße 2-4 · 35274 Kirchhain · Germany
Phone +49 6422 84-0 · Fax +49 6422 5100
www.emcowheaton.com · info-de@emcowheaton.com